

205LF Boiler Drain

Specification Sheet

FEATURES & BENEFITS

- Lead Free Brass
- 125 WOG
- With Stuffing Box
- Hose x 1/2" MIP / 1/2" Solder & 3/4" MIP
- Hose x FIP 1/2" & 3/4"



MATERIAL SPECIFICATIONS

No.	Part	Material
1	Wheel Nut	Hot Rolled SAE. 1010R
2	Name Plate	Aluminum
3	Handle Wheel	Cast Iron
4	Stem	Brass C89550
5	Packing Nut	Brass C89550
6	Packing	Rubber SAE No. 1052#
7	Bonnet	Brass C89550
8	Packing	Rubber SAE No. 1052#
9	Washer	Stainless Steel 304/306
10	Seat Packing	Rubber SAE No. 1052#
11	Seat Screw	Brass C89550
12	Body	Brass C89550

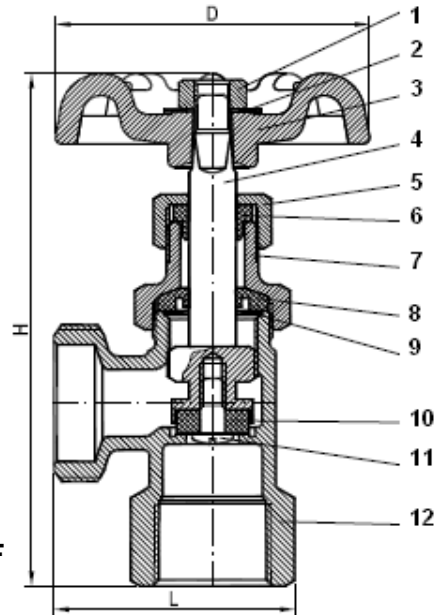
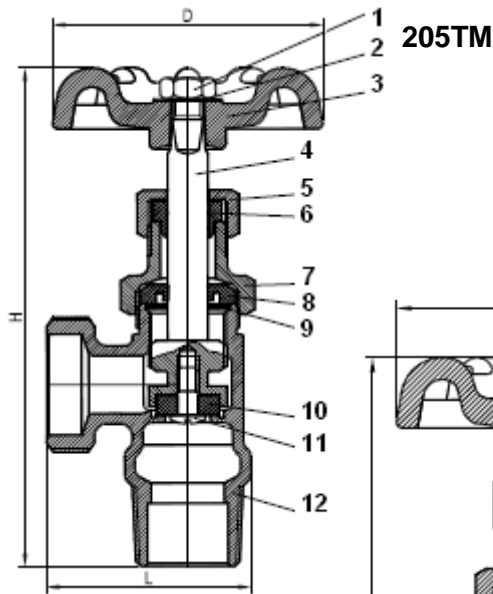

DIMENSIONS

Part #	Size	H	L	D
205TF3LF	1/2" Female	3.45	1.62	2.11
205TF4LF	3/4" Female	3.41	1.80	2.11
205TM3LF	1/2" Male	3.63	1.60	2.11
205TM4LF	3/4" Male	3.66	1.73	2.11

